

INSTRUCTIONS

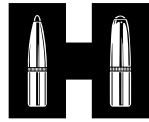

Hornady
Accurate. Deadly. Dependable.

PRECISION MEASUREMENT STATION



Item No. 050078

The Hornady® Precision Measurement Station

allows the reloader to sort components according to size and quality by comparing bullet ogive location, cartridge base to ogive location, headspace location and overall case length. In addition, this tool provides the reloader the ability to check true bullet to case concentricity and identify inconsistencies such as case and bullet dents. The base of the Hornady Precision Measurement Station weighs nearly eight pounds and has leveling feet for stability.

BILL OF MATERIALS

Item No.	Part Number	Description	Qty.
1	399750	Comparator Gauge Base	1
2	399751	Indicator Shaft	1
3	399771	Case Shoulder Holder	1
4	399770	Case Head Holder	1
5	399758	Comparator Holder	1
6	399762	BHCS, Flanged, 10-32 x 3/8	1
7	399210	BHCS, 10-32 x 1/4	4
8	399759	Dial Indicator Flat Attachment	1
9	399764	1/4-20 Lock Nut	4
10	399753	Indicator Holder 1	1
11	399754	Indicator Holder 2	1
12	399763	#6-32 T-Slot Nut	2
13	398523	Dial Indicator .0005	1
14	399752	1/4-20 Rubber Leveling Foot	4
15	69100	Bullet Comparator .224	1
16	69101	Bullet Comparator .243	1
17	69103	Bullet Comparator .257	1
18	69102	Bullet Comparator .264	1
19	69105	Bullet Comparator .277	1
20	69104	Bullet Comparator .284	1
21	69106	Bullet Comparator .308	1
22	399765	8-32 Brass Thumb Screw	1
23	69006	Thumb Screw OAL Comp Headspace	4
24	69024	Headspace Bushing "A" (.330)	1
25	69025	Headspace Bushing "B" (.350)	1
26	69026	Headspace Bushing "C" (.375)	1
27	69027	Headspace Bushing "D" (.400)	1
28	69028	Headspace Bushing "E" (.420)	1

EXPLODED VIEW

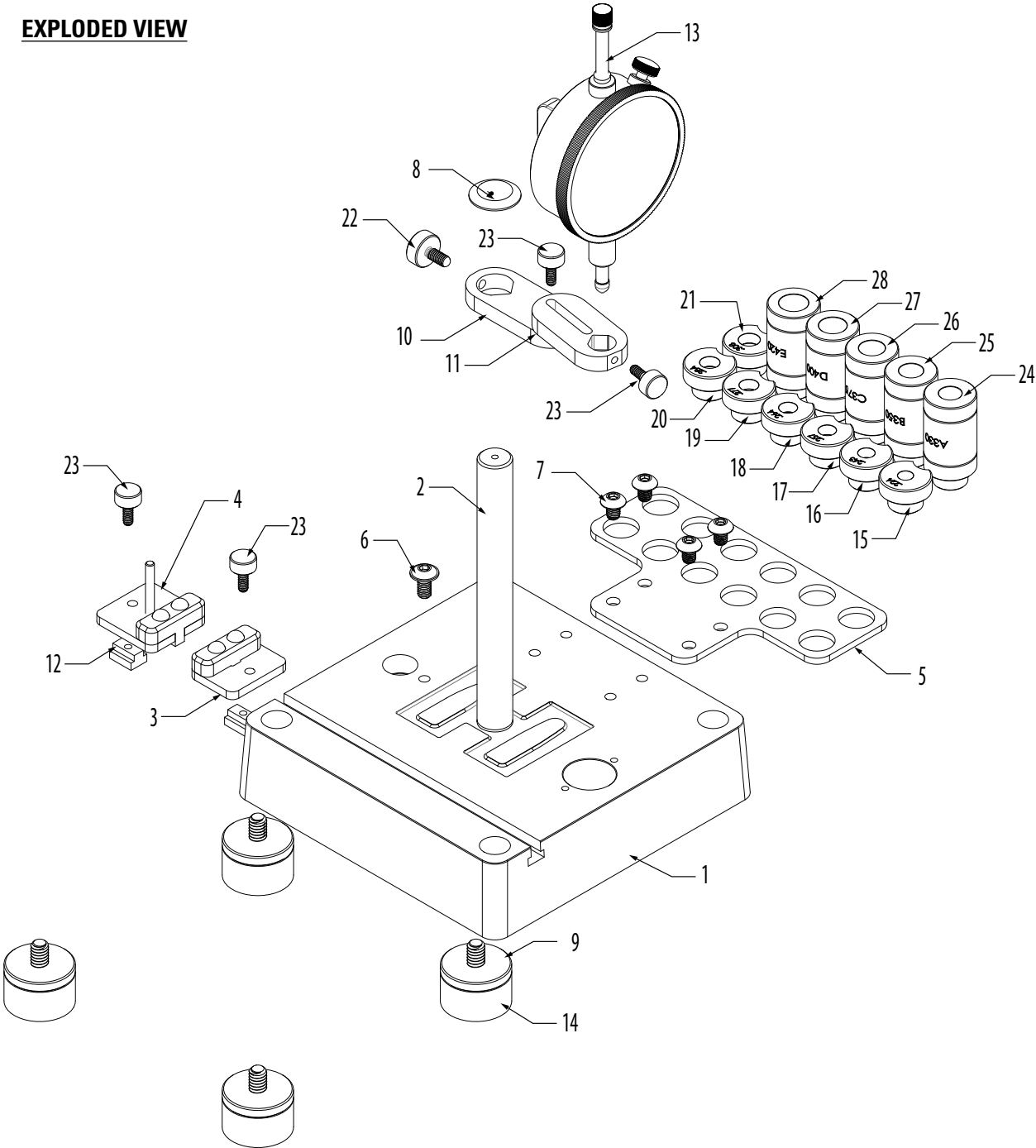

CHANGING INDICATOR ATTACHMENTS *(REFERENCE EXPLODED VIEW ON PG. 2)*

The Hornady .0005" Dial Indicator (13) comes with a ball tip installed. The Precision Measurement Station includes a Flat Attachment (8) for the Dial Indicator for different functions within the station.

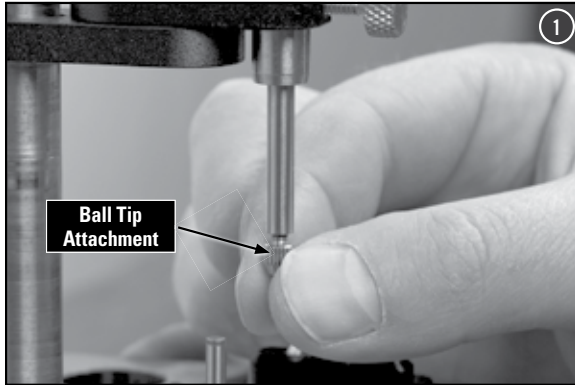

Remove the ball tip by grasping the knurled portion firmly between your fingers and turning counterclockwise. The first removal may be difficult, but **DO NOT** use pliers or any other mechanical means to remove the ball tip. This could damage the dial indicator and the tip.

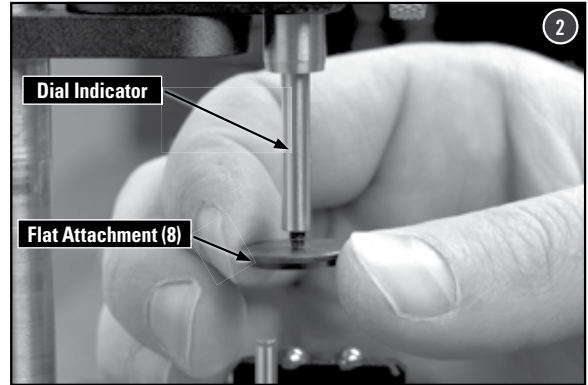

Remove the flat attachment (8) from the storage location on the top of the Indicator Shaft (2).

Thread the ball attachment into the storage location on the indicator shaft, then thread the flat attachment into the dial indicator.

USING CONCENTRICITY STATION *(REFERENCE EXPLODED VIEW ON PG. 2)*

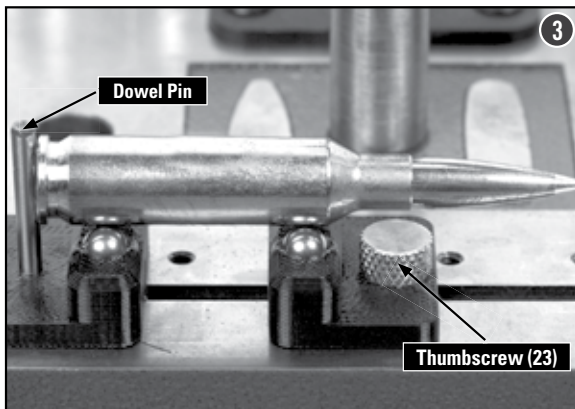

To begin, place a cartridge case or cartridge on the steel balls of the case shoulder holder (3) and case head holder (4). The case head should be pushed against the dowel pin.

Adjust the case shoulder holder by loosening the thumbscrew (23) and sliding it in the T-slot until the steel balls are located slightly behind the body/shoulder junction. Tighten the thumbscrew. Be sure the ball tip is installed on the dial indicator *(refer to step 1)*.

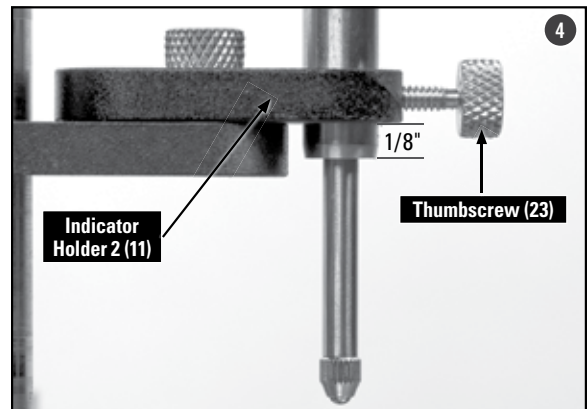

Loosen the thumbscrew (23) on the front of Indicator Holder 2 (11) and raise the dial indicator (13) in the holder until there is approximately an 1/8" from the bottom of the indicator shaft to the bottom of Indicator Holder 2. Tighten the thumbscrew.

USING CONCENTRICITY STATION (CONTINUED)

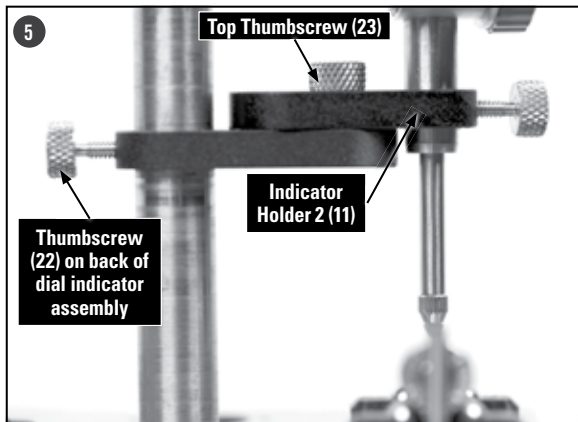

Loosen the thumbscrew (22) on the back of the dial indicator assembly. Rotate the entire assembly toward the concentricity station and adjust it so that the ball tip is about 1/8" above the bullet or case mouth. Tighten the thumbscrew.

Loosen the thumbscrew (23) on top of Indicator Holder 2 and position the dial indicator so the the ball tip is on the centerline of the bullet or case mouth. Tighten the thumbscrew.

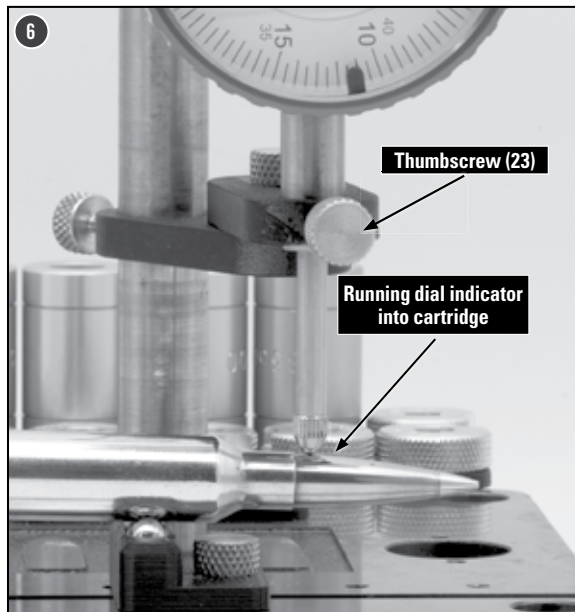

Loosen the thumbscrew on the front of Indicator Holder 2 and gently lower the dial indicator onto the neck of the case or bullet. The case/cartridge will move, but lower the indicator to roughly .100" of interference.

Place the cartridge or case back on the ball bearings. Hold the case firmly against the dowel pin while applying even pressure in the center of the case and rolling it on the ball bearings.

NOTE: For best results, check the concentricity of loaded ammunition just behind where the ogive and the bearing surface of the bullet meet. For best results on cases, check the concentricity as close to the case mouth as possible.

USING OGIVE COMPARATOR STATION *(REFERENCE EXPLODED VIEW ON PG. 2)*

The ogive comparator station is located to the left of the Hornady logo on your Precision Measurement Station.

To begin, remove the button head cap screw (6) from the ogive comparator station. Select the correct ogive comparator gauge (15-21) for the bullet diameter being used and place it in the hole. Replace the button head cap screw and tighten it into the notch cut out of the ogive comparator.

Be sure the flat attachment is installed in the dial indicator (refer to steps 1 & 2).

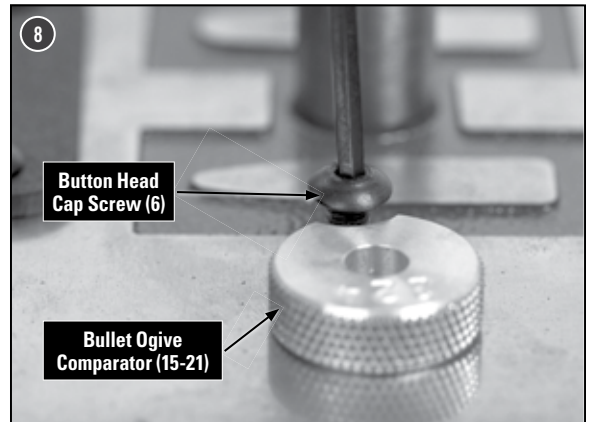

Loosen the thumbscrew (23) on the front of Indicator Holder 2 (11) and raise the dial indicator in the holder so there is approximately an 1/8-inch from the bottom of the indicator shaft to the bottom of Indicator Holder 2. Tighten the thumbscrew.

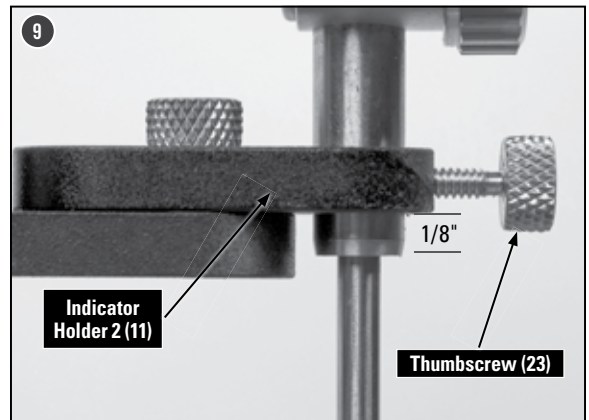

Place a bullet or cartridge in the ogive comparator. Loosen the thumbscrew (22) on the back of the dial indicator assembly and position the entire assembly to the Ogive Comparator Station so that the flat attachment is about 1/8-inch above the base of the bullet or cartridge. Tighten the thumbscrew.

Loosen the thumbscrew (23) on top of Indicator Holder 2, and adjust the dial indicator to the center of the bullet or cartridge. Tighten the thumbscrew.

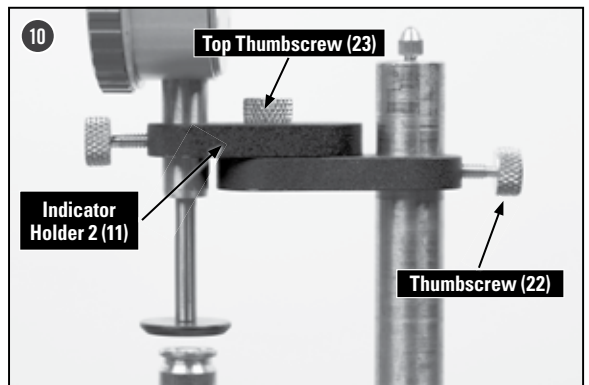

Loosen the thumbscrew on the front of Indicator Holder 2 and gently lower the dial indicator onto the base of the bullet, or cartridge if comparing base to ogive of loaded ammo. With approximately .100" of interference, tighten the thumbscrew.

You are now ready to begin comparing the ogive location of a bullet or base to the ogive of ammunition.

NOTE: To compare ogive location, the cartridge or bullet may need to be slightly moved or adjusted until the flat attachment contacts the bullet or cartridge base flat. Be sure the flat attachment is flush with the bullet or cartridge base before comparing.

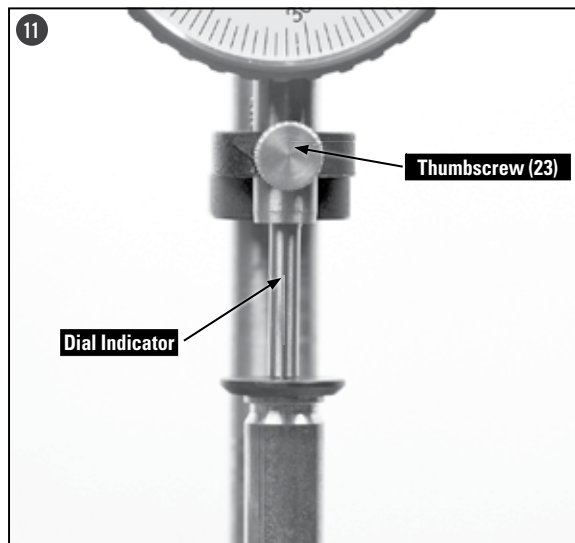

USING HEADSPACE COMPARATOR STATION (REFERENCE EXPLODED VIEW ON PG. 2)

Choose the proper Lock-N-Load® Headspace Bushing (24-28) from the chart below. If your cartridge is not listed, choose a comparator that contacts roughly in the center of the shoulder.

LOCK-N-LOAD® HEADSPACE BUSHINGS								
G .240" No. G240	A .330" No. A330	B .350" No. B350	C .375" No. C375		D .400" No. D400	E .420" No. E420		F .188" No. F188
17 Hornet	.17 Rem	22PPC	6mm Rem	300 H&H	223 WSSM	6.5 x 284	375 H&H Mag	Bushing "blank" with .188" diameter hole. Drill and Ream for sizes not listed.
	204 Ruger	22-250 Rem	257 Rob	7.62x39	243 WSSM	6.5 PRC	264 Win Mag	
	221 FB	6PPC, 6BR Rem	25-06 Rem	6.5x55	260 Rem	284 Win	7mm SAUM	
	222 Rem	250 Sav	270 Win	7mm WSM	270 WSM	7mm Rem Mag	7mm STW	
	222 Rem Mag	7BR Rem	7 x 57mm	30-40 Krag	7mm-08 Rem	7mm Ultra Mag	300 RSAUM	
	223 Rem	300 Blkout	280 Rem	6.5 Creedmoor	300 Sav	300 WSM	300 Win Mag	
	220 Swift	6.5 Grendel	30-30 Win	6.5 x47 Lapua	308 Win	300 Wby Mag	300 Ultra Mag	
			30-06	243 Win	35 Rem	325 WSM	8mm Rem Mag	
					338 Win Mag	338 Ultra Mag		
					350 Rem Mag	35 Whelan		

Place the Headspace Bushing in the hole to the right of the Hornady logo.

Be sure the flat attachment (8) is installed in the dial indicator (*refer to steps 1 & 2*).

Loosen the thumbscrew (23) on the front of Indicator Holder 2 (11) and raise the dial indicator in the holder until there is approximately an 1/8-inch from the bottom of the indicator shaft to the bottom of Indicator Holder 2. Tighten the thumbscrew (*see step 4 for picture reference*).

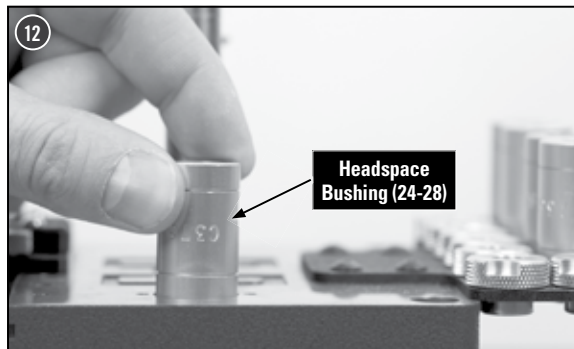

Place a cartridge case into the headspace comparator. Loosen the thumbscrew (22) on the back of the dial indicator assembly and position the indicator so that the flat attachment is about an 1/8-inch above cartridge case.

Tighten the thumbscrew.

Loosen the thumbscrew (23) on top of Indicator Holder 2 and center the dial indicator with the headspace comparator or cartridge case. Tighten the thumbscrew.

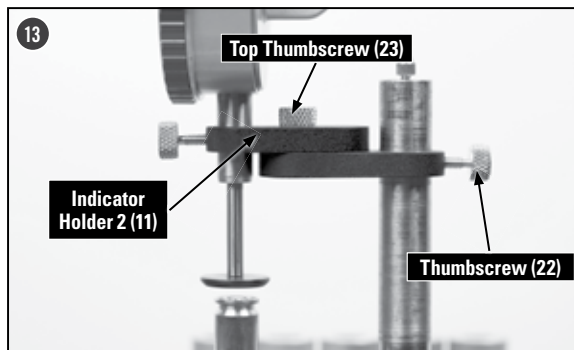

Loosen the thumbscrew on the front of indicator holder 2 and gently lower the dial indicator onto the base of the case. With approximately .100" of interference, tighten the thumbscrew.

You are now ready to begin comparing the headspace location of your cartridge cases.

NOTE: To compare headspace, the case may need to be slightly moved or adjusted until the flat attachment contacts the case head flat. Be sure the flat attachment is flush with the case head before comparing.

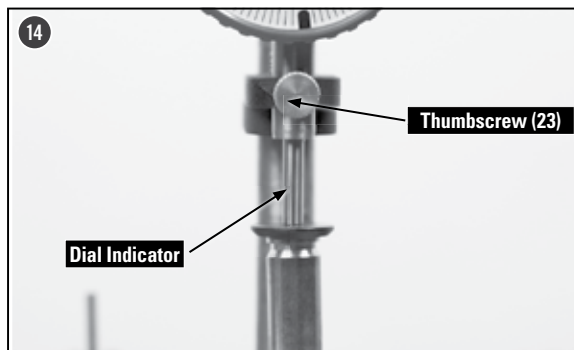

COMPARING OVERALL CASE LENGTH (REFERENCE EXPLODED VIEW ON PG. 2)

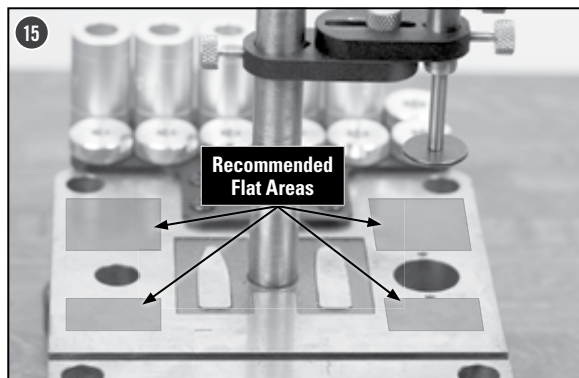

Pick a flat area on top of the Precision Measurement Station Base (1).

Be sure the flat attachment (8) is installed in the dial indicator *(refer to steps 1 & 2)*.

For ease of use, slide the case shoulder holder (3) and case head holder (4) to the left or right depending on the location chosen.

NOTE: They can even be removed from the T-slot.

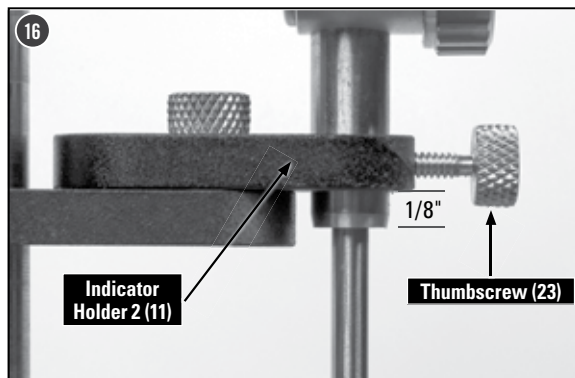

Loosen the thumbscrew (23) on the front of Indicator Holder 2 (11) and raise the dial indicator in the holder so there is approximately an 1/8" from the bottom of the indicator shaft to the bottom of Indicator Holder 2. Tighten the thumbscrew.

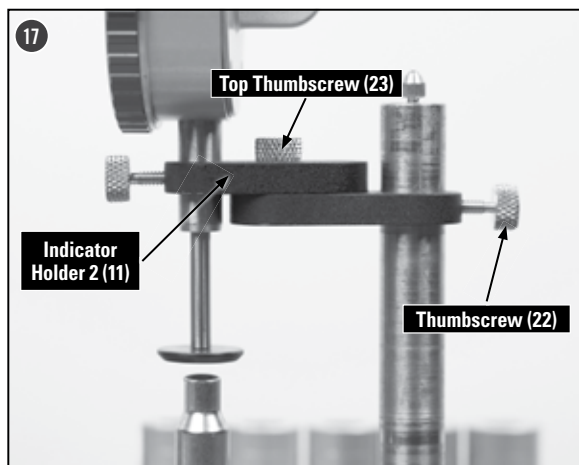

Place a case on the chosen flat section of the Precision Measurement Station Base. Loosen the thumbscrew (22) on the back of the dial indicator assembly and position the indicator so that the flat attachment is about an 1/8" above the case. Tighten the thumbscrew.

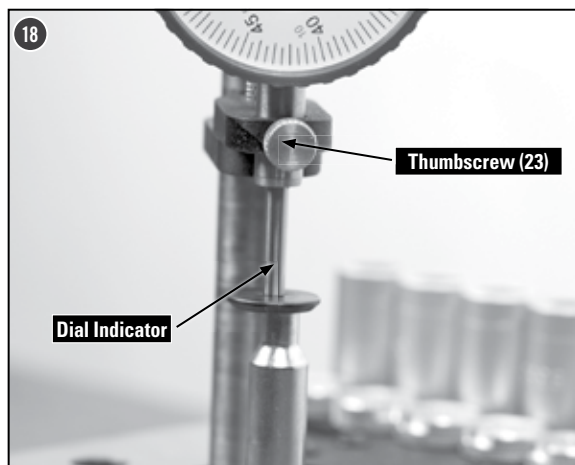

Loosen the thumbscrew on the front of Indicator Holder 2 and gently lower the dial indicator onto the mouth of the case. With approximately .100" of interference, tighten the thumbscrew.

You are now ready to begin comparing overall case length.

NOTE: For the most consistent comparison, perform this operation before the case has been primed.

USING THE FLAT AREAS OF THE BASE

The base of the Hornady Precision Measurement Station has extra flat space designed for a wide array of measurements and comparisons.

To perform these:

Adjust the dial indicator over the flat portion to be used.

Choose the attachment necessary for the measurement being observed.

Begin to compare.

SOME USEFUL FUNCTIONS FOR FLAT AREAS

Bullet Diameter

TO COMPARE:

Use the flat attachment for the dial indicator.

Place the bullet on its side on the Precision Measurement Station Base and begin comparing.

TO MEASURE:

Although a micrometer (Hornady part #050072) is a better method of measuring bullet diameter, the Hornady Precision Measurement station can be used to measure in 1/2 thousandths increments (.0005). Use the flat attachment for the dial indicator.

Move the dial indicator assembly down until the flat attachment makes contact with the Precision Measurement Station Base. Zero the dial indicator by loosening the bezel lock and rotating the bezel until the large indicator needle is pointing at "0". Tighten the bezel lock.

The .0005 dial indicator makes one revolution every .050. The small indicator needle on the face of the dial indicator is the tenths indicator. As the dial indicator shaft is moved upwards the tenths indicator needle rotates clockwise. If the tenths indicator needle is pointing to a number or between that number and the next line then the reading is the last number. However, if the tenths indicator needle is pointing to the line in between the numbers or in between that line and the next number then the result is the last number plus .050.

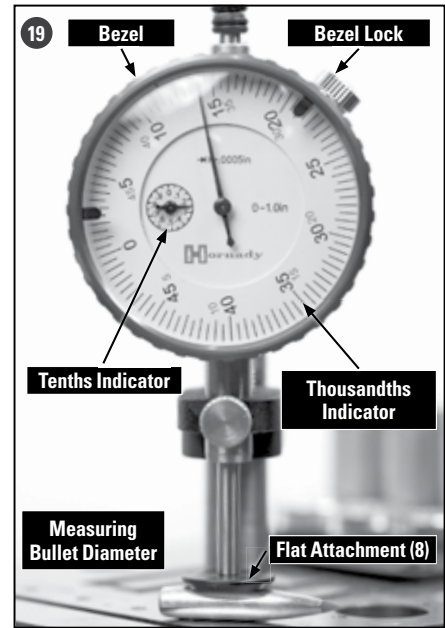

The large indicator needle on the face of the dial indicator is the thousandths indicator. Much like the tenths indicator needle, as the indicator shaft is moved upwards the thousandths indicator needle moves clockwise. Each line represents 1/2 of a thousandth (.0005), and the numbers are placed every 5 thousandths (.005). For example, the first line past 25 is .0255, the second line past is .026, the third line past is .0265, and so on.

Note the number the tenths indicator needle is pointing to.

Place a bullet sideways underneath the flat attachment.

Now read the new number from the tenths indicator needle and subtract this reading from the initial reading.

Read the number from the thousandths indicator needle, and add it to the result of the tenths indicator you determined earlier. The number derived is the diameter of your bullet to the nearest 1/2 thousandths increment (.0005).

For example, in image #19 when the flat attachment was adjusted to make contact with the Precision Measurement Station base, the dial indicator read .0000 on both the tenths indicator needle and the thousandths indicator needle. The bullet was then placed underneath the flat attachment.

The number that the tenths indicator needle is pointing to is .25. Subtract from it, the initial reading (.25 - .0000 = .2500). The number that the thousands indicator needle is pointing to is .014. Add this to the tenths figure (.250+.014=.264). The result is your bullet diameter.

Case Mouth Squareness

Use the flat attachment for the dial indicator.

Zero the dial indicator on one side of the case mouth.

Rotate the cartridge case while noting the readings on the dial indicator.

NOTE: *It is important to keep consistent downward pressure on the case to assure the case head is flat on the Precision Measurement Station Base.*



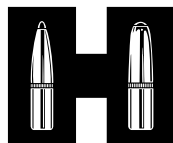

Hornady[®]
Accurate. Deadly. Dependable.

P.O. Box 1848, Grand Island, Nebraska 68802-1848
308-382-1390 • 800-338-3220 • Fax: 308-382-5761
hornady.com/contact