

INSTRUCTION MANUAL



 **AIMAN**

THERMAL IMAGING DEVICE





CAIMAN



CLIP-ON THERMAL IMAGING DEVICE



<i>Device overview</i>	8
<i>Delivery set</i>	10
<i>Application</i>	11
<i>Controls</i>	12
<i>Menu</i>	14
<i>Navigation</i>	14
<i>Appearance</i>	14
<i>Mode Monocular / Clip-on</i>	24
<i>Battery extender</i>	25
<i>Battery extender installation</i>	25
<i>Battery charging</i>	27
<i>Operation with the batteries</i>	28
<i>Tips for proper battery care and use</i>	29
<i>Cable connection</i>	30
<i>Attachment</i>	31
<i>Installation of the front of the daytime rifle scope</i>	31
<i>Operating with the device</i>	33
<i>GUI</i>	34
<i>Software installation</i>	34
<i>Storage</i>	39
<i>Transportation</i>	40
<i>Product description and principle of operation</i>	41
<i>Product description</i>	41
<i>Principle of operation</i>	41
<i>Technical Parameters</i>	42

ATTENTION!

	<p><i>Make sure to carefully read the present manual before using the device to ensure its safe exploitation.</i></p>
	<p><i>Thoroughly test the device before use after it has been left in storage for a long period of time.</i></p>
	<p><i>Disassembling the device is prohibited, except in authorized repair centers.</i></p>
	<p><i>The external optical surfaces should be clean at all times. Touching the optical surfaces with bare hands is not recommended.</i></p>
	<p><i>Sand and sea water can damage the optical coatings!</i></p>
	<p><i>Do not point the device directly at the sun!</i></p>
	<p><i>Image performance (quality) depends on the scenery and the atmosphere conditions. The contrast of the image may vary as a function of the time of day due to the effect of the sun. For example, at sunset objects will have absorbed different levels of heat resulting in greater temperature differences and better contrast.</i></p>
	<p><i>When storing the device for a longer period of time, the batteries have to be removed and stored in polyethylene bags to prevent contact with metal. It is recommended to recharge the batteries every two to three months.</i></p>

	<p><i>Condensation can cause fogging of the external optical surfaces! Condensation occurs when:</i></p> <ul style="list-style-type: none"> • <i>When moving the device from cold to warm place or vice versa;</i> • <i>The device's temperature differs significantly from the ambient one;</i> • <i>Using the device in places with high humidity.</i> <p><i>When the temperature of the device is equalized with the ambient one, the condensation disappears. Use the towel to remove moisture. Condensation also can be prevented with anti-fogging sprays or with sacrificial lenses on the oculars or with the provided rubber pieces.</i></p> <p><i>Condensation on the objective does not affect the performance of the device!</i></p>
	<p><i>Clean the lens surfaces with the Lens Pen®.</i></p>

DEVICE OVERVIEW

NOTE



All images used in this instruction manual are for illustrative purposes only. Actual product may vary due to product enhancement.

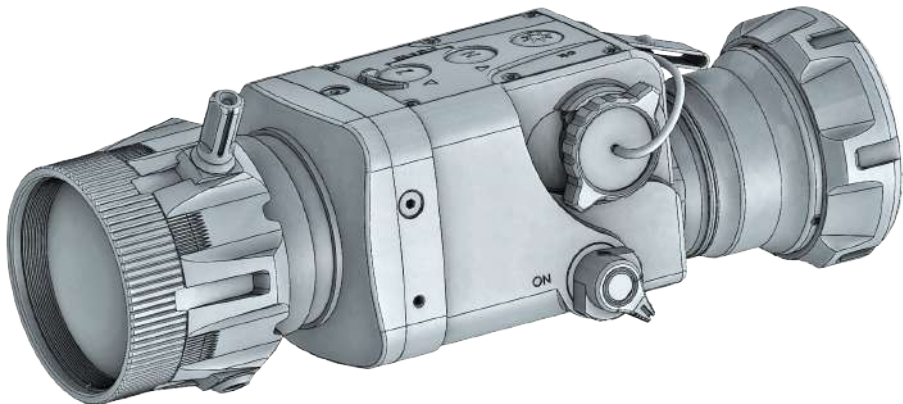

ATTACHMENT PLACE

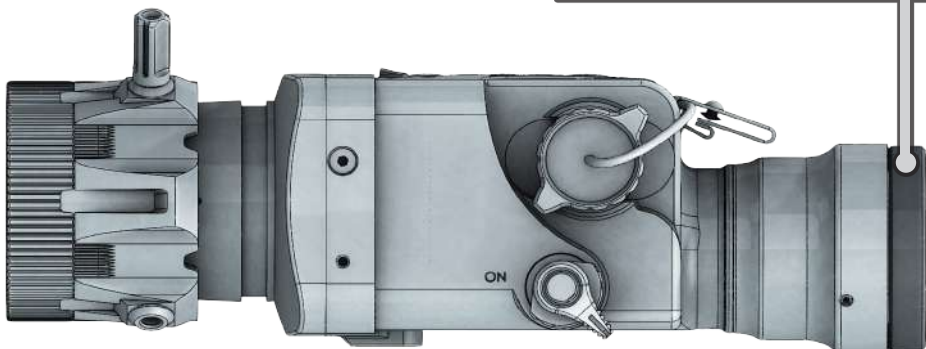

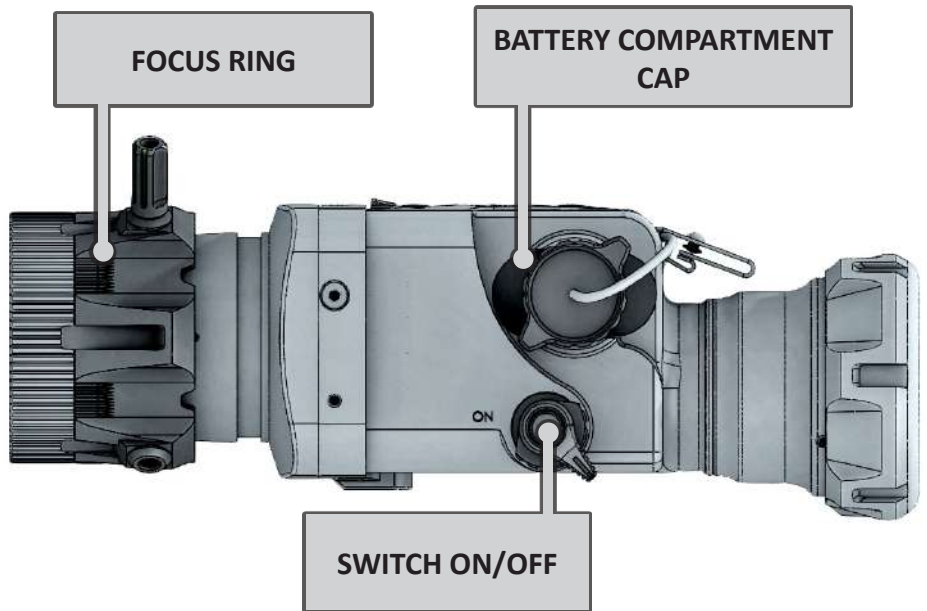
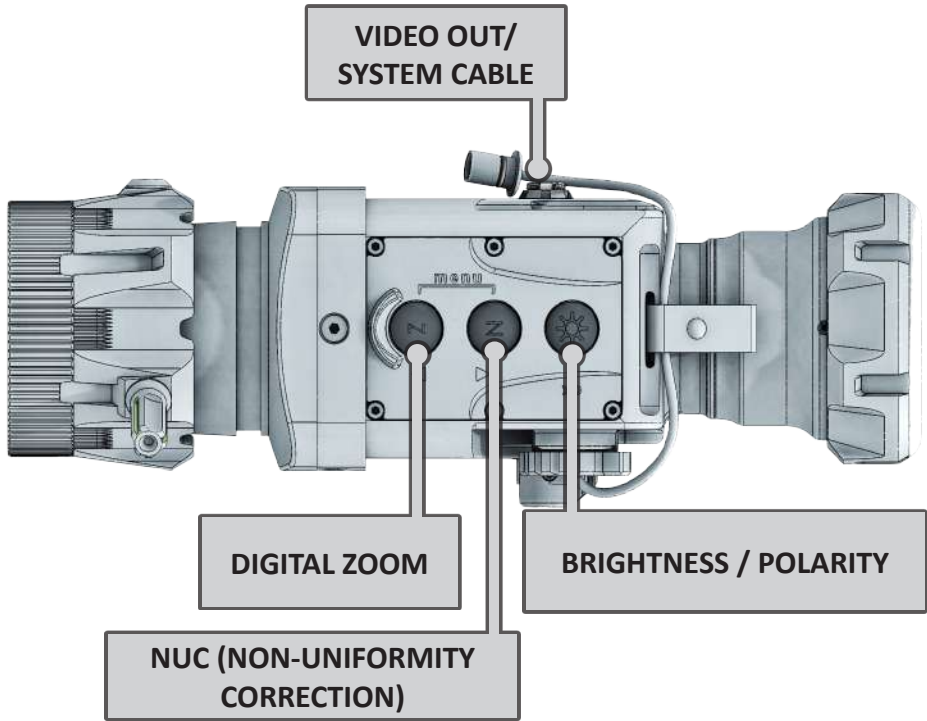

DELIVERY SET

N	DESCRIPTION	QTY.	
1	<i>CAIMAN clip-on thermal device</i>	✓	1
2	<i>Carrying pouch</i>		
3	<i>Hard case</i>		
4	<i>Neckstrap set</i>		
5	<i>Cleaning napkin</i>		
6	<i>LensPen®</i>		
7	<i>Battery extender</i>		
8	<i>Adapter 220 V AC</i>		
9	<i>Objective cap</i>		
10	<i>Additional polymeric focus ring</i>		
11	<i>Quality Certificate</i>		
12	<i>User Manual</i>		
13	<i>Wi Fi Transmitter (optional)</i>		
14			
15			

APPLICATION

CAIMAN clip-on thermal device is a specially designed for installation in front of daytime rifle scopes or other observation devices as well as a stand-alone hand-held device, ensuring clear view in variety of environmental conditions, including fog, rain, snow, smoke, total darkness.

The sophisticated design of the CAIMAN Clip-On Thermal Device eliminates the need to remove the day sighting equipment since the CAIMAN mounts directly in line with a standard daytime rifle scopes.



Such a combination allows the user to avoid re-zeroing the rifle every time the sight set-up is changed since the primary sight remains undisturbed. The point of impact remains the same no matter how often or how many times the clip-on is mounted.

CAIMAN is based on proven 640x480 pixels 17 μm Microbolometer technology, with high thermal sensitivity and excellent dynamic range. The housing is made of durable and extremely resistant magnesium alloy and is coated with matt anti-reflective coating.

CONTROLS

ATTENTION!



The main operations are performed through the buttons ,  and .

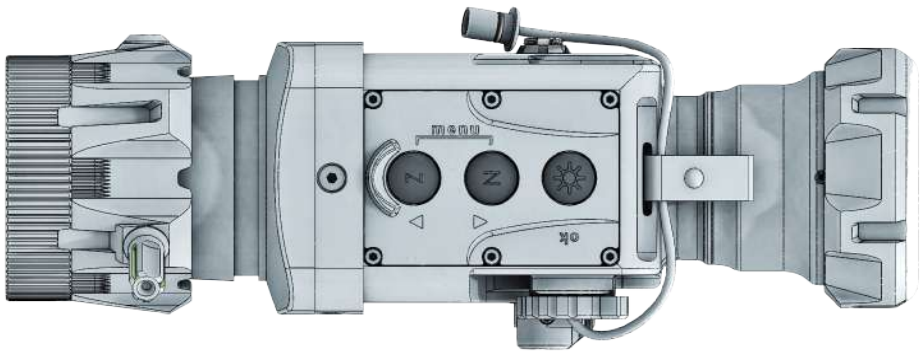

NOTE



The integrated functions of the device exceed the number of controls. Some features are triggered by a combination of buttons or temporary pressing and holding the buttons.

ATTENTION!



Turn off the device after usage, otherwise, you can permanently damage the batteries!

Z



DIGITAL ZOOM

Press the  button to activate the digital zoom x2, press twice - x4.

The current digital zoom is shown at the top-right corner of the screen.



NOTE



The digital zoom reduces the quality of the image! Digital zoom is inactive in clip-on mode.

By pressing and holding the  button (more than 2 sec) a snapshot of the image is taken and stored in the memory of the device. An indication  (saved) is displayed.

N



NUC (NON-UNIFORMITY CORRECTION)

The picture quality highly depends on the sensor temperature. Minimal change in temperature is reflected in visible imperfections of the picture - vertical lines, the appearance of light and dark pixels, etc. This effect is strongly expressed during a cold start of the product, when the matrix / sensor begins to change temperature sharply. In order to improve the picture quality, a Calibration procedure is activated, which can be Auto, Manual, External or Internal. We recommend the use of Auto mode, in which the calibration frequency depends on the temperature characteristics of the sensor. The NUC algorithm can be activated manually by pressing the  button. Pressing and holding the NUC button (for more than 2 seconds) activates/deactivates the Auto NUC function. When Auto NUC function is activated, the following symbol  will be displayed on the screen. The symbol  will be highlighted in red as a warning 2 seconds before the NUC is performed automatically.

When the Auto NUC function is deactivated the symbol  will disappear and the NUC procedure will be carried out manually only when pressing the  button.

**LUMINANCE / POLARITY**

The device has three fixed and one user adjustable values of the display luminance, marked with the following icons: 

When using the device in low lighting conditions and for an extended period of time, consider lowering the brightness levels to extend the battery life and to avoid eye fatigue. Single short press of the button  shows the current Luminance value. Pressing the button again in close succession will cycle through the available luminance values. The value of the manual luminance option can be configured through the user menu. Press and hold the  button for more than 2 seconds to invert the image, i.e. warm object appear in black hot or in white hot and vice-versa. The change of polarity is denoted by the BH or WH symbols that appear on the screen for 2 seconds.





MENU

Navigation





ATTENTION!



The buttons ,  and  are dual purpose buttons!

Besides the main and secondary functions, they serve also for entering and navigation through the menu. To activate the menu, press the  and  buttons simultaneously. Then use the  and  button to move the cursor, and  button to select the function.

Appearance

    	Range Finder			    	
	Settings			Language English/Deutsch/ Magyar	
	Image		Brightness	NUC Type Internal/External	
	Mode	Monocular	Contrast	Standby On/Off	
	Exit	Clip-On	Weather Type Hot/Normal/Wet	Alignment	
				Filters Filter 1/Filter 2/ Filter 3	Back
				Palette Rainbow/Rain/Isotherm Black Hot/White Hot/ Red Hot	
				Snapshot View/Erse All	
				Back	

RF (Range Finder)

Stadiametric RF function allows measuring of approx. distance to a known object.

In order to do that select the object type you are observing. Align the marker so that the base of the observed object fits the bottom line and the upper line fits the top of the object (see the picture below). Once the object is fitted in the marker borders (up-down arrows), on the left side of the screen the approx. distance to the object is displayed.

To exit the RF mode press the OK button.

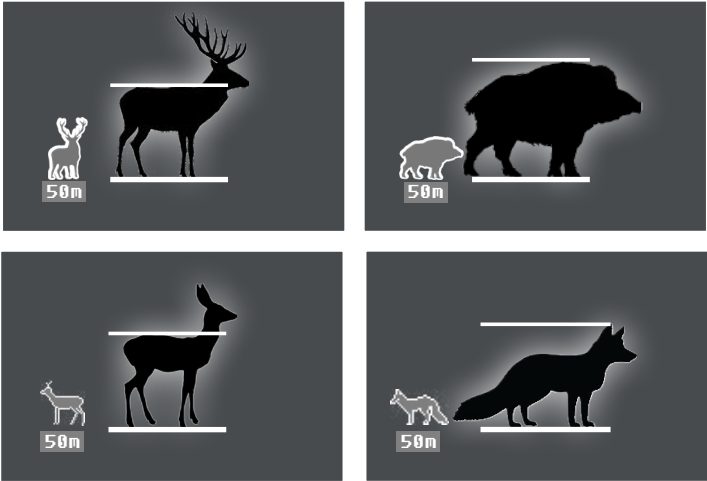

Settings

Language

Select the preferred language, using this section. The default language is English.

RF	
	Language English/Deutsch/ Magyar
	NUC Type Internal/External
	Standby On/Off
	Alignment
	Back

NUC Type

The non-uniformity correction (NUC) of the signal is a complex electronic process, which requires a uniform temperature body in front of the detector or the objective lens.

For the convenience of the user, the device has a built-in motorized mechanism for performing NUC procedure by automatically dropping a miniature shutter plate in front of the detector. This process takes less than a second and is accompanied by an acoustic noise resembling a click.

Selecting the **NUC type** changes the NUC mode between **Internal** and **External**.

In situations requiring maximum suppression of the external noise, the device can operate in **External shutter mode**, which isolates the operation of the motorized mechanism.

When the **External shutter mode** is activated, the motorized mechanism of the shutter is blocked, **Auto NUC** function is deactivated.

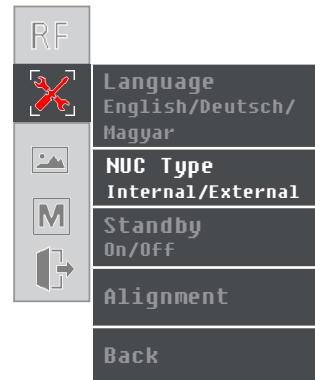

In that case, the mechanism will be performed by the user, who must cover the objective lens, before pressing **N**. In order to cover the objective lens use the hand or the protective cap, otherwise, the image of the display will resemble **the negative** effect of the observed scene.

Upon power on, the device automatically performs two consecutive NUC-cycles. During this period of time, it is desirable to cover the objective lens with the protective cap or with the hand. These actions are necessary only when the **External shutter mode** is activated.

ATTENTION!



In extreme low or high temperatures, always use external (NUC) shutter mode.

Standby

When **Standby** function is on, the device will be powered on every time, when the tilt angle is less than 45° to both sides (fig. 1) and 60° upwards and downwards (fig. 2). As soon as these conditions are not fulfilled, the device will automatically switch to standby mode.

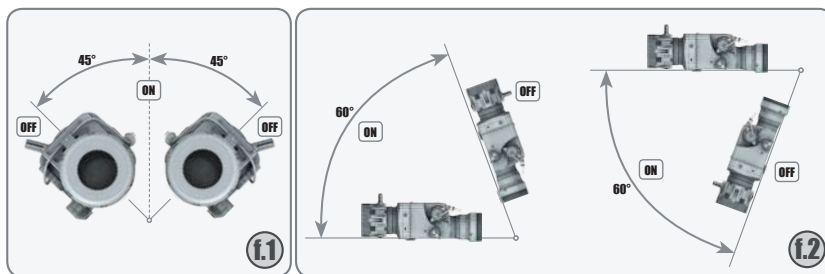

Alignment

With **Alignment** function, you can precisely align the optical axes of the day sight and the clip-on attachment. The manufacturing process of the device ensures the shooting precision tolerance within 5 to 7 cm at 100 m. By this alignment function, you can achieve much better results in the accuracy.

Alignment is made electronically by pressing the **Z** and **N** buttons, while being in the menu **Settings** > **Alignment** > **Left/Right, Up/Down** (in clip-on mode only).

In position **X: 0, Y: 0** the image is in center of the screen of the device. By using the alignment function user moves the image in all directions.

If the impact point is on the left of the target, the image should be moved to the right, increasing the value of **X**, and vice versa.

The adjustment is limited to 3 steps in each direction. Each step corresponds to approx. 3 cm at 100 m. If the need for alignment exceeds the limit of 10 steps, please contact your vendor.

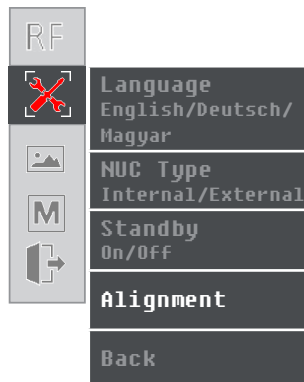
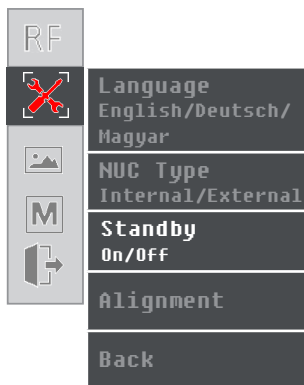



Image

Brightness

Selecting **Brightness** gives the opportunity to set your own user-defined level of image brightness.



Brightness is not related to the Luminance adjustment performed by the button !

RF	
	
	Brightness
M	Contrast
	Weather Type Hot/Normal/Wet
	Filters Filter 1/Filter 2/ Filter 3
	Palette Rainbow/Rain/Isotherm Black Hot/White Hot/ Red Hot
	Snapshot View/Erase All
	Back

Contrast

Selecting **Contrast** gives the opportunity to set your own user-defined level of image contrast (Gain).

Increasing the contrast value will ensure better object contrasting and easier detection. However this will decrease the details on the observed object. Decreasing the contrast value will make the details visible.

RF	
	
	Brightness
M	Contrast
	Weather Type Hot/Normal/Wet
	Filters Filter 1/Filter 2/ Filter 3
	Palette Rainbow/Rain/Isotherm Black Hot/White Hot/ Red Hot
	Snapshot View/Erase All
	Back



Weather Type

Image quality is strongly depending on weather conditions. When the weather is wet (fog, rain, etc.) the dynamic range of the scene is reduced, causing low contrast performance of the device. We developed a special filter, that enhances the details in the low contrast image by wet weather conditions (incl. fog and haze). You may choose between 3 filters - **Hot**, **Normal**, and **Wet**.

RF

✂

M

	Brightness
	Contrast
	Weather Type Hot/Normal/Wet
	Filters Filter 1/Filter 2/ Filter 3
	Palette Rainbow/Rain/Isotherm Black Hot/White Hot/ Red Hot
	Snapshot View/Erase All
	Back



NOTE



*By good weather conditions please select **Normal**. Otherwise, the image will be noisy.*

Filters

These filters affect the object edges by eliminating the speckle noise, but reduces the sharpness of the image.

RF	
	Brightness
	Contrast
	Weather Type Hot/Normal/Wet
	Filters Filter 1/Filter 2/ Filter 3
	Palette Rainbow/Rain/Isotherm Black Hot/White Hot/ Red Hot
	Snapshot View/Erse All
	Back

Filter 1 - Standard image filter mode for observation.



Filter 2 - Image sharpening filter. Objects have sharper contours for maximum detail performance at long distances.



Filter 3 - Image filter suitable for observing objects within high ambient temperature and small temperature difference in between.



NOTE 
Filter 3 is not recommended for low contrast conditions such as foggy or rainy weather.

Palette

A variety of color palettes can be used. In different palette modes, the object's temperature is reflected in the coloring.

Rainbow/Rain/Isotherm/Black Hot/White Hot/Red Hot

Rainbow, Rain - Color modes suitable to observe on an area with similar heat energy allowing to detect objects and slight temperature changes between them.

Isotherm - the objects above the threshold temperature are colored in different shades of red. The temperature threshold can be set (increase/decrease) by the temperature scale shown.



White Hot and **Black Hot** - Choosing Black Hot (warmer objects appear in black) and White Hot (warmer objects appear in white) is up to user's personal preference.

Red Hot - recommended mode for prolonged observation. The image is red black to minimize the blue light emitting from the displays and allows more comfort for the eyes.

Increasing the threshold value ignores the colorization of the colder objects.

This option is highly dependent from the distance to the object. It is highly recommended to try different values of the threshold in the daily usage to find the right value for your personal preference.

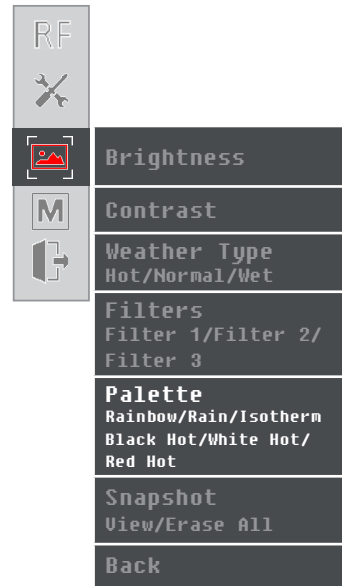

Snapshot

The snapshot function is performed by pressing and holding the **Z** button. Snapshots are stored in the internal memory of the device. You can store up to 20 images. You can review the images from the Snapshot menu.

Images can be downloaded only via USB cable and the provided GUI.

Erase All subfunction deletes all images from the internal memory of the device. The deletion process takes 1 min.

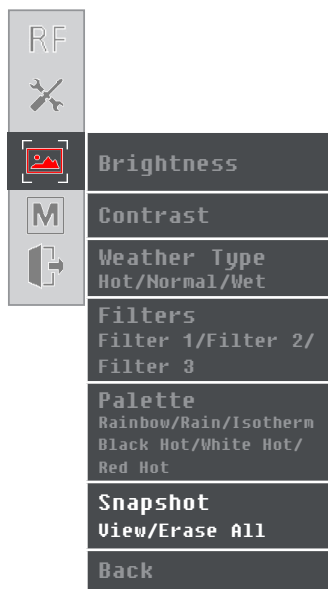

MODE Monocular/Clip-on

To use CAIMAN as a clip-on device select **Mode>Clip-on** from the menu. All important On-screen elements are displayed in the central area of the image. The reason is the reduced field of view of the daysight by higher magnifications. The digital zoom is locked. The **Z** button calls up the **Infobox**, which gives the information about the current settings of the device.

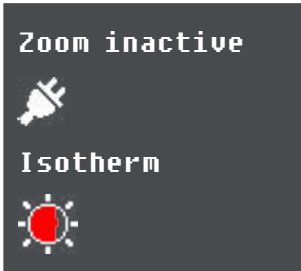

Reaching a low battery state the device gives a warning in the top left corner of the central area. There is a possibility to ignore it by pressing the **Z** button.

NOTE



It is recommended to use up to 3x magnification of the primary optical unit in order to keep the menu and all submenus visible in clip-on mode.

BATTERY EXTENDER

Caiman is powered by Li Ion Battery Extender with ergonomic design and easy installation, ensuring >4 hours of continuous operation.

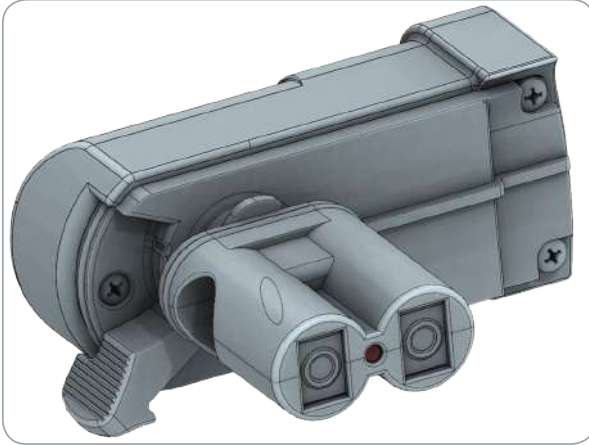

Battery Extender

Battery Extender Installation

- 1 Place the locking thumb of Battery Extender on top position, as shown on the image and plug Battery Extender in device's battery compartment until it stops.

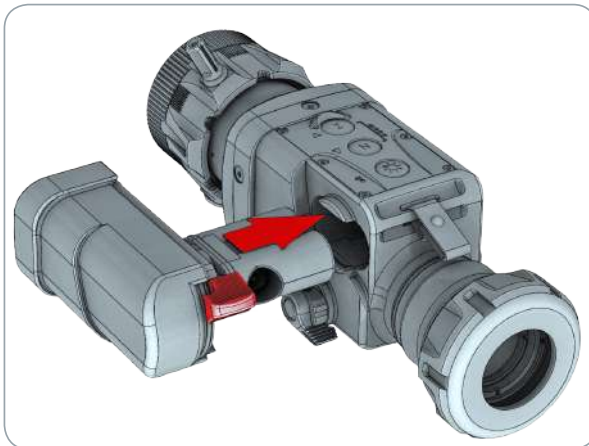

- ② Push the thumb down until it stops.

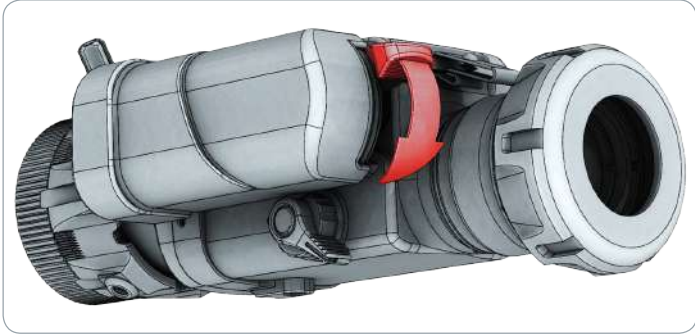

- ③ Properly installed Battery Extender.

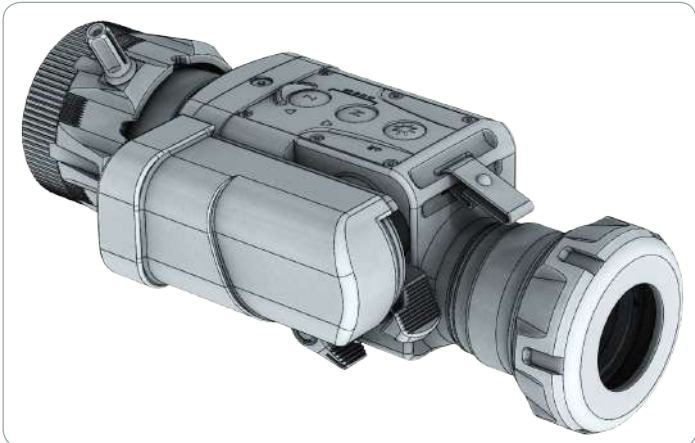

Battery Charging

External Battery Pack has internal battery management.

Battery Extender is supplied with External Special Charger. After plugging in the charger, the charge mode of Battery Extender starts. Charging time is approximately 5 hours.



Charging mode is indicated by a red LED light.

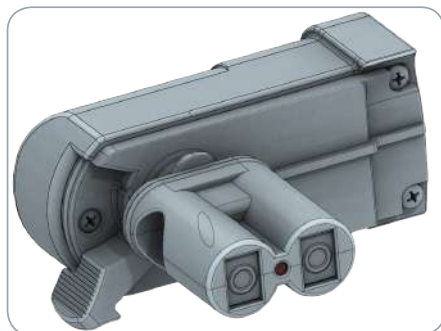

When the batteries are fully charged the red LED light stops.

ATTENTION!



Always use only the original charger in the delivery set of the device.



OPERATION WITH THE BATTERIES

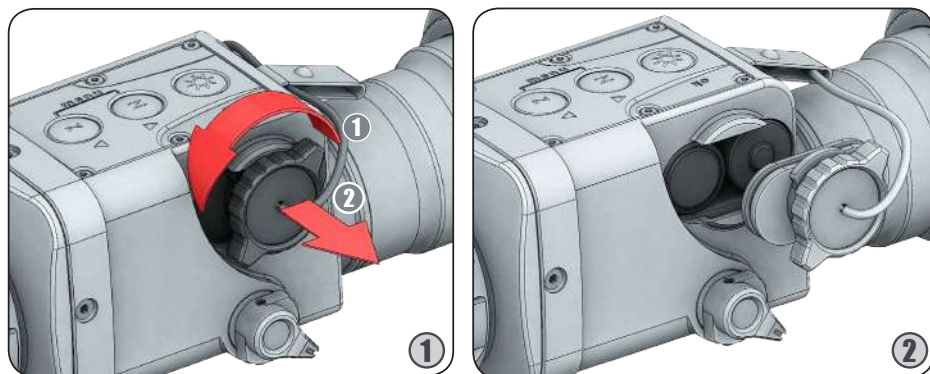





1. Turn counterclockwise to unlock the locking screw on the lid of the battery compartment (located on the left side of the device);
2. Put the batteries in the compartment, minding the correct polarity as shown inside the compartment!
3. To close the battery compartment hermetically, press firmly the lid compartment and rotate clockwise until the mechanism locks.

CAIMAN can be also powered by two pieces of CR123A rechargeable Li-Ion batteries or two pieces of CR123 Lithium batteries. These options allow using your device with commercially available batteries.

The Li-Ion batteries are automatically recognized by the device.

When using lithium cells, you have to “inform” the device by following these steps:





- ① Make sure, that the device is in “power off” state;
- ② Insert the two lithium batteries in the device (following the upper instructions);
- ③ Press and hold  (do not release it);
- ④ Power on the device (with pressed );
- ⑤ Hold  until the display lights up;
- ⑥ Release .

NOTE



*When intending using only lithium cells, these steps should be performed only one time!
The operation time with CR123 Lithium and CR123A Li-Ion batteries, may be reduced to <2 hours.*

The battery levels are as follows:

	battery is fully charged
	battery has 75% residual charge
	battery has 50% residual charge
	battery has 25% residual charge
	battery is fully discharged

ATTENTION!



On Lithium batteries External NUC is activated and Internal NUC is disabled.

Tips For Proper Battery Care And Use

- Use the correct size and type of battery, specified in the technical description and user manual.
- Keep battery contact surfaces and battery compartment contacts clean. For this purpose, you can use a clean pencil rubber or a rough cloth each time you replace batteries.
- Remove the batteries from the device when it is left in storage for a longer period of time.
- Make sure that you insert batteries into your device properly (with the + (plus) and – (minus) in the correct position).
- Store batteries in a dry place at normal room temperature.
- Extreme temperatures reduce battery performance.
- Do not attempt to recharge a battery, unless the battery specifically is marked “rechargeable.”
- Do not dump-out used lithium batteries! They need to be kept in appropriate places.

CABLE CONNECTION

CAIMAN can be remotely controlled and adjusted through interface system cable. Video cable serves for external displaying and recording of the observed scene.

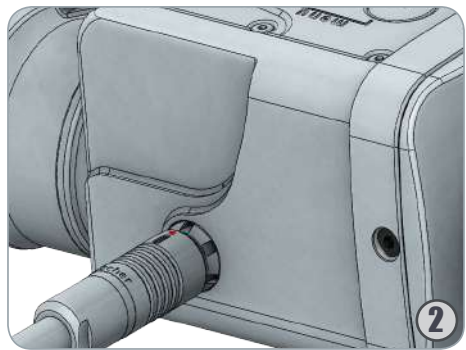
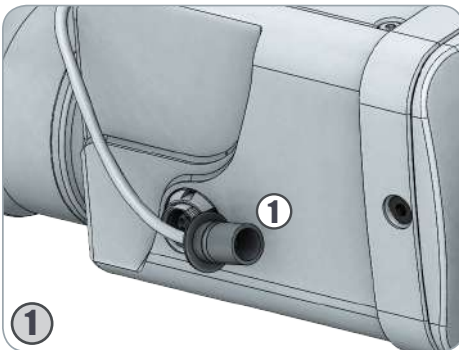

Pull the cap ① of the panel connector (located on the right side of the device). The cables enable the connection with an external device like a PC, laptop or monitor with analog video input.

One side of both cables end with a 7-pin Fischer connector. When connecting it with the device through the panel connector make sure the red markings (both on cable Fischer connector and panel connector device) match.

ATTACHMENT

Installation of front of the daytime rifle scope

The clip-on thermal device CAIMAN comes with M52x0.75 adapter ring (② on the next page), that matches different types of fixed adapter rings (③ on the next page).

NOTE!



During shooting with the clip-on thermal device CAIMAN attached to the daytime rifle scope with help of the fixed adapter the adapter could move along the daytime rifle scope. The size of this movement depends on the tightening force of the locking thumb and recoil force of weapon and could be equal to 1 mm on each shot. This movement is allowed and does not affect on the impact point. The position of the adapter should be controlled after each shot in the shooting sequence.

TIP



Mark both - the clip-on and the daytime rifle scope and check markers for displacement after each shot.

WARNING!



Use of this device may be restricted by national regulations. You should consult with local authorities prior to use the clip-on thermal device CAIMAN.

Mount your clip-on thermal device CAIMAN in front of the daytime rifle scope as follows:

- 1 Turn the adapter ring ② clockwise and screw it into the thread ①, located on the back side of the device until stops.

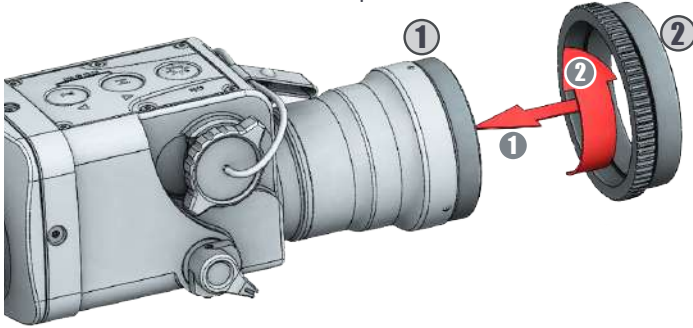

- 2 Turn the fixed adapter ring ③ clockwise and screw it on the outer thread of the adapter ring ②.

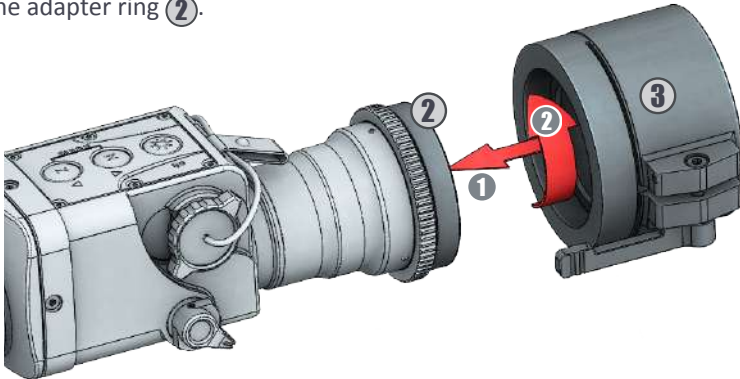

- 3 Position the clip-on thermal device CAIMAN to the daytime rifle scope with the control buttons located on top.

Put the clip-on thermal device CAIMAN with the fixed adapter on the front of the daytime rifle scope ④ and fix it by the adapter thumb ⑤.

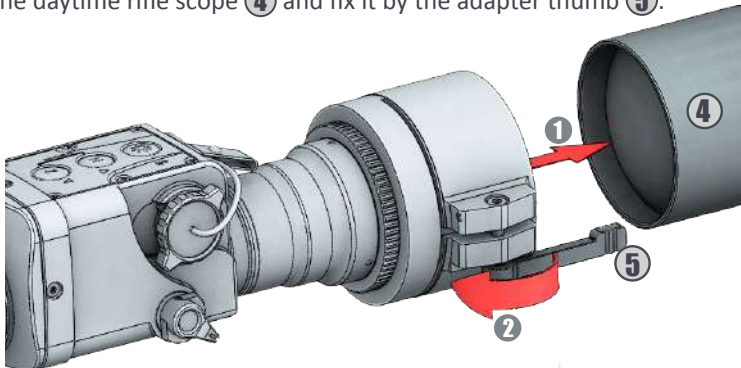

OPERATING WITH THE DEVICE

The advantage to being mounted in front of a daytime rifle scope is that the clip-on thermal device does not affect the riflescope zero and keeps all tactical features of a daytime rifle scope intact.

After attaching the clip-on thermal device CAIMAN to the daytime rifle scope follow the next steps for operation with the device:

- ➊ Always check the adjustment of the daytime rifle scope (diopter adjustment, parallax, adjustment, etc.)
- ➋ Open the objective lens cap.
- ➌ Switch on the device.
- ➍ Set the required magnification of a daytime rifle scope. Choose the object of observation and focus the objective lens of the device by using the lens focusing ring of the front of the objective.
- ➎ The fire adjustment of the system that includes both the daytime rifle scope and CAIMAN clip-on thermal device should be performed in accordance with the instructions for adjustment of the daytime rifle scope.
- ➏ Turn off the device after finished working and remove the batteries from the battery compartment to avoid battery leakage.
- ➐ Close the objective cover.

NOTE!



When mounted in front of the daytime rifle scope CAIMAN can change zeroing as not more than 3 cm. This is connected with changes in the weapon balance, light distortions in the daytime rifle scope, technological limits of the adjustment of the CAIMAN clip-on thermal device.

NOTE!



For maximum image quality through the daytime rifle scope, we recommend using rifle scope magnification up to 3x.

GUI

Software installation

After starting the **Startup.exe** file, an installation confirmation window will appear. Once GUI has been started, the following window will appear. Connect the device to a personal computer using the USB-Fischer system cable, power on the device and select **Yes**.



A window will appear with a drop-down menu which will allow the user to select the preferred serial communication port (i.e. the COM where the device is connected to). Once the port has been selected, the user can proceed by selecting **Connect**.



The port number and baud rate will be displayed on the status bar at the bottom of the main window alongside the type of the device.

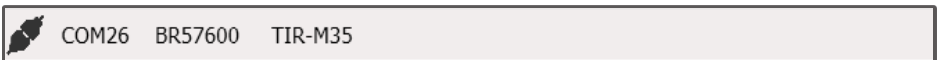

The current settings of the device are displayed in the main tab.



- By clicking the NUC button, the non-uniformity correction procedure will start.
- In the ZOOM panel, the digital magnification can be selected – x2, x4 or to revert it back to the initial setting – x1.
- In the palette drop-down menu, five palette options are available to the user – White Hot, Black Hot, Rain, Rainbow and Isotherm.

When second tab (NUC Settings) is selected, a tab with two panels: **NUC On/Off** and **Time Interval** will appear.



With the **SET** button, the user can save the desired setting for the automatic NUC time interval for the device.



The **Snapshot Download** tab allows the user to download and save pictures from the internal memory of the device to a personal computer.

- From the drop-down menu in the Download Snapshot panel, the user can select a snapshot by selecting its corresponding number.
- **VIEW** - By clicking **VIEW** button the snapshot will be downloaded from the device and displayed in Snapshot View panel.

NOTE: *The user must wait for the full downloading procedure before doing anything else.*

- **SAVE** - By clicking the **SAVE** button the selected image can be saved on the personal computer the application is being used on.
- **ERASE ALL** – By clicking on the **ERASE ALL** button, all images from the flash memory will be erased permanently.

STORAGE

To maximize the life of your device and to protect it from damage we recommend storing it in the individual packaging in which you received it.

Before storing it, clean obligatory the device (if on its surface there are moisture, dust or traces of dirt)!

Make sure that there are no traces of moisture, and the battery compartment is empty!

It is also possible for a short periods of time device to be stored in a suitable soft pack, bag or cartridge box.

The premises in which the device is kept for long term have to be dry, enclosed, unheated and ventilated.

During the storage should not be allowed exposure to aggressive environments, temperatures below -50°C and above $+60^{\circ}\text{C}$, a relative humidity greater than 80%, and prolonged periods of direct sunlight.

TRANSPORTATION

The product should be transported only with its original packaging and its individual shockproof transport suitcase.

Before each transportation, the product should be neatly packed in its original packaging (transport bag) and all other items and accessories should be carefully and steadily placed in the bag. After that, the bag should be steadily placed in the transport suitcase.

PRODUCT DESCRIPTION AND PRINCIPLE OF OPERATION

Product description

The device allows detection and identification of objects that emit energy in the infra-red spectrum. The equipment operates in rain, fog and total darkness in a completely passive mode (without additional illumination). The active matrix is microbolometer, working in the wavelength range from 7 to 14 μm . The unique design of the device makes it reliable and ergonomic.

The body is made of strong, ultra-lightweight magnesium alloy and with applied matt anti-reflective coating. The manipulation of the basic functions of the device is made by buttons and serial interface organized as OSD (on-screen-display). There is a possibility of changing the reticles and ballistic corrections through a serial interface using custom software.

Principle of operation

The principle of operation of a non-cooled system is illustrated schematically on the picture below. Only the main blocks are shown and their functional sequence.

A special germanium objective lens focuses the infrared energy emitted by all of the objects in the field of view of the device. The focused radiation is scanned by an array of infrared-detector elements. The detector elements create a detailed temperature pattern of the observed scene called a thermogram. The signal generated by the detector elements is passed true analog-to-digital converter and translated into discrete electric impulses. The impulses are sent to an image-processing unit, a circuit board with a dedicated chip that improves the image quality and converts the information from the elements into data for the display. The signal-processing unit sends the information to the display, where it appears as various shades of gray depending on the intensity of the infrared emission. The combination of the impulses from all of the detector elements creates the final image.

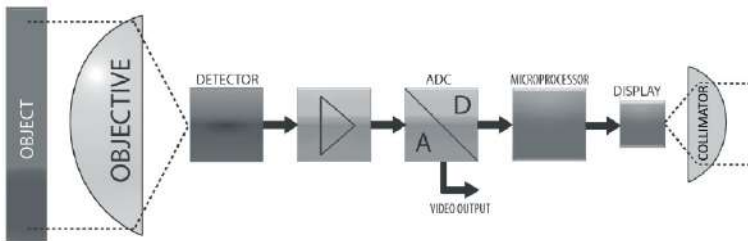

TECHNICAL PARAMETERS

FOCAL PLANE ARRAY (FPA)	
Type	Microbolometer
Pixel Count (Resolution)	640 x 480
Pitch Size	17 μm
Spectral Response	7 \div 14 μm
Thermal Sensitivity (NETD)	< 50 mK @ F / 1.0
THERMAL IMAGING PERFORMANCE	
Brightness / Contrast	Automatic / Advanced Image Processing
Start-up Time	< 5 sec
Image Polarity	User Selectable (White Hot / Black Hot)
Menu	Dropdown Menu / OSD
IFOV	0.3 mRad
NUC	Automatic / Manual
OPTICS	
Focal Length of the Objective Lens	50 mm
FOV	12.4°(H) X 9.3°(V)
F/#	1.1
Material & Coating	Germanium, Hard Carbon Coating on the External Surface

VIDEO	
<i>Analog Video Output Format</i>	<i>CCIR (PAL) or RS-170 (NTSC)</i>
<i>Frame Rate</i>	<i>25 Hz (PAL) / 30 Hz (NTSC)</i>
<i>Digital Zoom</i>	<i>x2, x4</i>
<i>Viewfinder Luminance</i>	<i>Manual via OSD</i>
<i>Image Capture</i>	<i>Up to 20 Images (Onboard storage, Download via System Cable)</i>
POWER	
<i>Power Source</i>	<i>2 x CR 123 Lithium, 2 x RCR 123 Li-Ion 2 x 16650 Li-Ion (with Extender for Batteries)</i>
<i>Operating Times</i>	<i>~ 2 Hours with Lithium Batteries @ 25°C ~ 4 Hours with 16650 with Extender</i>
STATIC RANGE PERFORMANCE	
<small>Calculated for geometrical average (\sqrt{HxW}). NOTE: The distances defined are calculated in geometrical values only, not accounting the atmospheric conditions.</small>	
<i>Human Detection Range</i>	<i>~ 1320 m</i>
<i>Human Recognition Range</i>	<i>~ 440 m</i>
<i>Vehicle Detection Range</i>	<i>~ 3380 m</i>
<i>Vehicle Recognition Range</i>	<i>~ 1120 m</i>
ENVIRONMENTAL CHARACTERISTICS	
<i>Operating Temperature Range</i>	<i>-30°C to +50°C</i>
<i>Storage Temperature Range</i>	<i>-50°C to +60°C</i>
<i>Shock Resistance</i>	<i>Tested with .375 H&H and .338 Lapua Magnum</i>
<i>Mechanical Vibration</i>	<i>Sinusoidal, 40 m/s², 10 to 80 Hz</i>
<i>Index of Protection</i>	<i>IP 66, IP 67 (optional), Nitrogen Filled</i>
PHYSICAL CHARACTERISTICS	
<i>Dimensions H x W x L</i>	<i>68 x 68 x 198 mm</i>
<i>Weight without Batteries</i>	<i>~ 580 g</i>

NOTES

A series of horizontal dotted lines for writing notes.

NOTES

A series of horizontal dotted lines for writing notes.

NOTES

A series of horizontal dotted lines for writing notes.

NITEHOG



CAIMAN



**Email: info@nitehog.eu
Tel.: +49 30 26375088
Mob.: +49 176 72170712
Nitehog Europe GmbH
Pistoriusstraße 6A,
DE-13086 Berlin, Deutschland**

